

ComfoAir 350 Basic
Installer manual

zehnder

always
around you

Heating

Cooling

Fresh Air

Clean Air



All rights reserved.

This manual has been compiled with the utmost care. The publisher cannot be held liable for any damage caused as a result of missing or incorrect information in this manual. In case of disputes the Dutch version of these instructions will be binding.

Table of Contents

Preface	1
1 INTRODUCTION	1
1.1 Warranty and liability	1
1.1.1 Guarantee conditions	1
1.1.2 Liability	1
1.2 Safety	2
1.2.1 Safety regulations	2
1.2.2 Safety provisions and measures	2
1.2.3 Pictograms used	2
2 FOR THE FITTER	3
2.1 ComfoAir configuration	3
2.2 Technical specifications	4
2.3 Dimension sketch	6
2.4 Installation conditions	7
2.5 Installation of the ComfoAir	7
2.5.1 Transport and unpacking	7
2.5.2 Checking the delivery	7
2.6 Mounting of the ComfoAir	7
2.6.1 Mounting on the wall	7
2.6.2 Connection of the air ducts	8
2.6.3 Connection of the condensation drain	8
2.7 Commissioning the ComfoAir	9
2.7.1 Display on the unit	9
2.7.2 P menus for the installer	10
2.8 Programming air specifications	13
2.9 Maintenance by the installer	14
2.9.1 Inspecting and cleaning the heat exchanger	14
2.9.2 Inspecting and cleaning the fans	15
2.10 Malfunctions	16
2.10.1 Malfunction alerts on the digital operating device	16
2.10.2 3-position switch with malfunction indicator	16
2.10.3 What to do in the event of a malfunction / Troubleshooting	17
2.10.4 Malfunctions (or problems) without alerts	21
2.11 Service parts	22
2.12 Wiring diagram: ComfoAir 350 Basic – LEFT-HAND version	23
2.13 Wiring diagram: ComfoAir 350 Basic – RIGHT-HAND version	24
2.14 EEC declaration of conformity	25

Preface



Carefully read this manual before use.

This manual provides all the information required for safe and optimal installation and maintenance of the ComfoAir 350 Basic. It is also intended as a reference for servicing, so that this can be carried out in a responsible manner. The device is subject to continuous development and improvement. As a result, the ComfoAir 350 Basic may slightly differ from the descriptions.

1 Introduction

The device's name is ComfoAir 350 Basic. In the following it will be referred to as ComfoAir.

The ComfoAir is a balanced ventilation system with heat recovery in order to create healthy, balanced and energy-efficient ventilation in houses. The ComfoAir has a CE marking on the identification plate. The identification plate can be found on top of the ComfoAir.

1.1 Warranty and liability

1.1.1 Guarantee conditions

The ComfoAir is covered by a manufacturer's warranty for a period of 24 months after fitting up to a maximum of 30 months after the date of manufacture. Warranty claims may only be submitted for material faults and/or construction faults arising during the warranty period. In the case of a warranty claim, the ComfoAir must not be dismantled without written permission from the manufacturer. Spare parts are only covered by guarantee, if they were supplied by the manufacturer and have been installed by an approved installer.

The warranty becomes invalid if:

- The guarantee period has elapsed;
- The device is used without filters;
- Parts are used that have not been supplied by the manufacturer;
- Non-authorized changes or modifications have been made to the unit.

1.1.2 Liability

The ComfoAir has been designed and manufactured for use in balanced ventilation systems incorporating Zehnder heat recovery systems. Any other application is seen as inappropriate use and can result in damage to the ComfoAir or personal injury, for which the manufacturer cannot be held liable.

The manufacturer is not liable for any damage originating from:

- Non-compliance with the safety, operating and maintenance instructions in this manual;
- The use of components not supplied or recommended by the manufacturer.
Responsibility for the use of such components lies entirely with the installer;
- Normal wear and tear.

1.2 Safety

1.2.1 Safety regulations

Always comply with safety regulations in this manual. Non-compliance with the safety regulations, warnings, notes and instructions in this manual can cause personal injury or damage to the ComfoAir.

- The ComfoAir may only be installed, connected, rendered operational and maintained by an appropriately approved installer, unless otherwise indicated in this manual;
- Installation of the ComfoAir must be carried out in accordance with the general and locally applicable construction, safety and installation instructions of the local council, electricity and water boards or other agencies;
- Observe the safety regulations, warnings, comments and instructions as prescribed in this manual at all times;
- Keep this manual with the ComfoAir throughout its life;
- Instructions with regard to cleaning or replacing the filters of the intake and exhaust valves must be carefully observed;
- The specifications stated in this document may not be changed;
- Modifying the ComfoAir is not allowed;
- The ComfoAir is only suitable for connection to 230V 50Hz mains;
- It is recommended to take out a maintenance contract so that the device is checked on a regular basis. The supplier can provide a list of registered installers nearby.

1.2.2 Safety provisions and measures

- The ComfoAir cannot be opened without using tools;
- It should not be possible to touch the fans, therefore ducting must be connected to the ComfoAir at a minimum duct length of 900mm.

1.2.3 Pictograms used

The following pictograms are used in this manual:



Point of attention.



Risk of:

- ***damage to the device;***
- ***performance of the device is compromised if instructions are not observed carefully.***



Risk of personal injury for the user or installer.

2 For the Fitter

2.1 ComfoAir configuration

The standard ComfoAir configuration consists of:

- External casing (A) of coated sheeting;
- Interior (B) of high-quality, expanded polypropylene EPP;
- 4 connections (C) for the air ducts;
- 2 plate filters (D) for air purification. Filter classification: outside air G4, return air G4;
- 2 energy-efficient DC motors (E) with high-efficient fan;
- HE (High efficient) heat exchanger (F);
- Control circuit board (H) with connections for the fans, the bypass, temperature sensors (T1 to T4), the 3-position switch with or without malfunction indicator (optional) and the bathroom switch (optional);
- Identification plate (I) detailing information on the ComfoAir (not visible);
- Condensation drain (J) to drain the condensation of the warm return air;
- Sticker (K) detailing the air connections (not visible);
- Cable (L) for power supply (not visible).

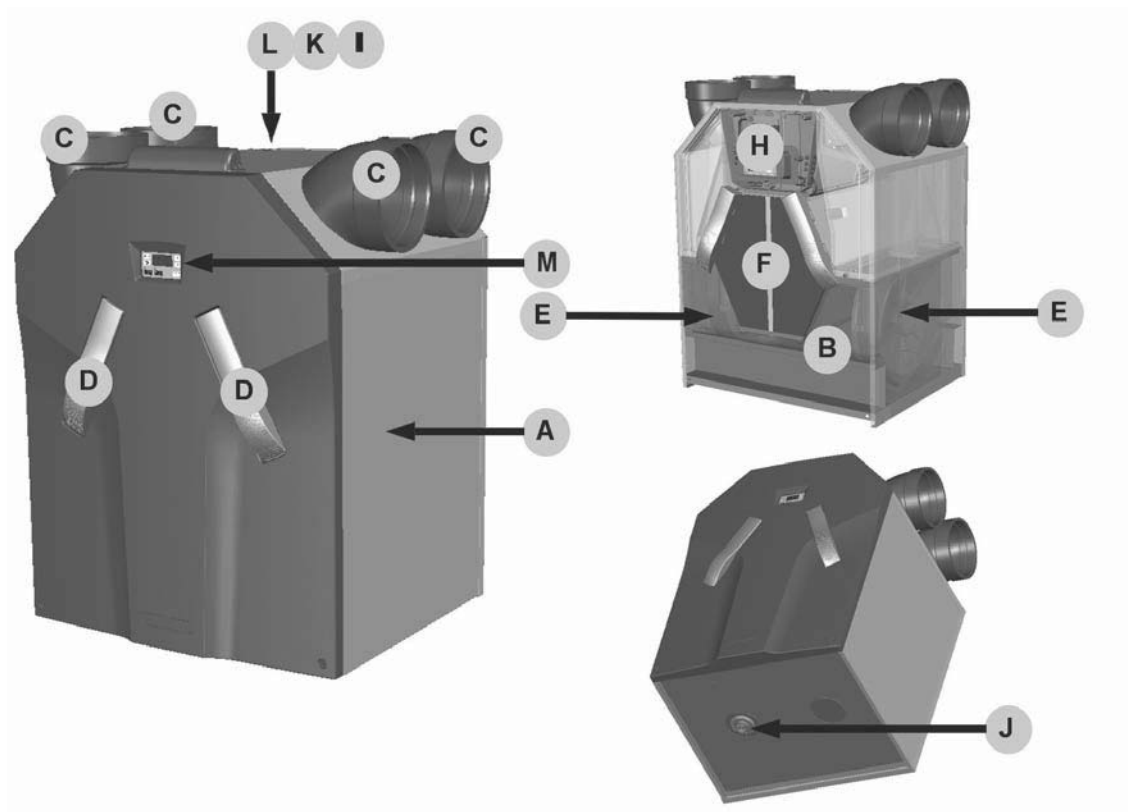

2.2 Technical specifications

ComfoAir 350 nL (normal air volumes)		
Position	Ventilation capacity	Power
Low Setting	100 m ³ /h at 20 Pa	21 W
Medium Setting	150 m ³ /h at 65 Pa	44 W
High Setting	225 m ³ /h at 150 Pa	105 W
Maximum	325 m ³ /h at 235 Pa	243 W
Position	Ventilation capacity	Current
Low Setting	100 m ³ /h at 20 Pa	0.17 A
Medium Setting	150 m ³ /h at 65 Pa	0.35 A
High Setting	225 m ³ /h at 150 Pa	0.81 A
Maximum	325 m ³ /h at 235 Pa	1.77 A

Electricity		
Power supply		230/50 V/Hz
Cos.phi		0,50 - 0,60

Supply fan noise level (at 0 m)		
Position	Ventilation capacity	Sound power
Low Setting	100 m ³ /h at 20 Pa	49 dB(A)
Medium Setting	150 m ³ /h at 65 Pa	59 dB(A)
High Setting	225 m ³ /h at 150 Pa	70 dB(A)
Maximum	325 m ³ /h at 235 Pa	75 dB(A)

Exhaust fan noise level (at 0 m)		
Position	Ventilation capacity	Sound power
Low Setting	100 m ³ /h at 20 Pa	43 dB(A)
Medium Setting	150 m ³ /h at 65 Pa	48 dB(A)
High Setting	225 m ³ /h at 150 Pa	55 dB(A)
Maximum	325 m ³ /h at 235 Pa	61 dB(A)

ComfoAir 350 HL (high air volumes)		
Position	Ventilation capacity	Power
Low Setting	125 m ³ /h at 25 Pa	27 W
Medium Setting	225 m ³ /h at 150 Pa	105 W
High Setting	300 m ³ /h at 230 Pa	196 W
Maximum	325 m ³ /h at 235 Pa	243 W
Position	Ventilation capacity	Current
Low Setting	125 m ³ /h at 25 Pa	0.21 A
Medium Setting	225 m ³ /h at 150 Pa	0.81 A
High Setting	300 m ³ /h at 230 Pa	1.42 A
Maximum	325 m ³ /h at 235 Pa	1.77 A

Electricity		
Power supply		230/50 V/Hz
Cos.phi		0,50 - 0,60

Supply fan noise level (at 0 m)		
Position	Ventilation capacity	Sound power
Low Setting	125 m ³ /h at 25 Pa	54 dB(A)
Medium Setting	225 m ³ /h at 150 Pa	67 dB(A)
High Setting	300 m ³ /h at 230 Pa	73 dB(A)
Maximum	325 m ³ /h at 235 Pa	75 dB(A)

Exhaust fan noise level (at 0 m)		
Position	Ventilation capacity	Sound power
Low Setting	125 m ³ /h at 25 Pa	45 dB(A)
Medium Setting	225 m ³ /h at 150 Pa	55 dB(A)
High Setting	300 m ³ /h at 230 Pa	59 dB(A)
Maximum	325 m ³ /h at 235 Pa	61 dB(A)

General Specifications		
HE Exchanger Material		Polystyrene
Interior Material		(E)PP / PA / PC
Thermal Yield		95%
Mass		39 kg

2.3 Dimension sketch

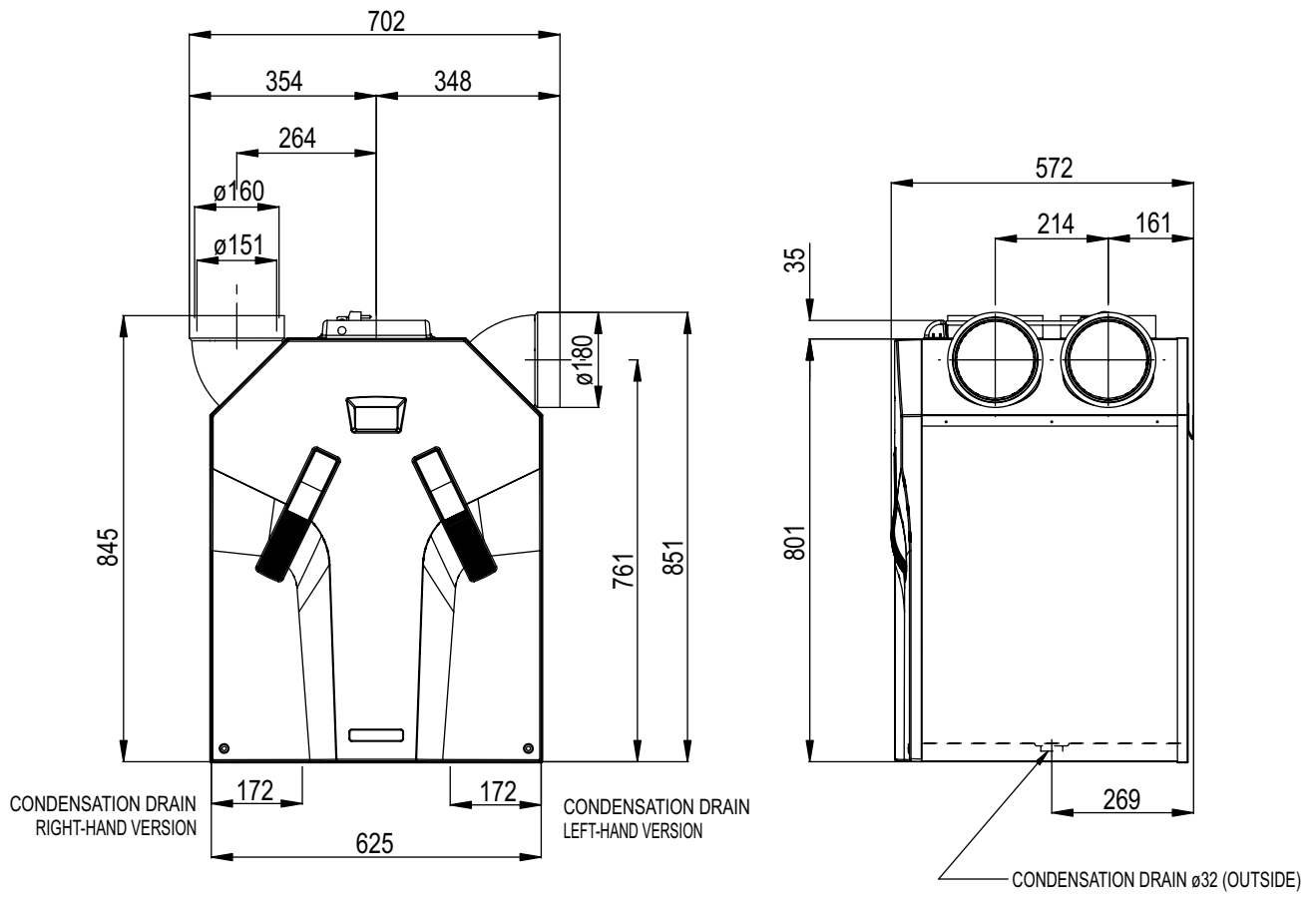

2.4 Installation conditions

In order to determine whether the ComfoAir can be installed in a certain area, the following aspects must be taken into account:

- The ComfoAir must be installed according to the general and locally applicable safety and installation regulations of power and water companies, as well as the instructions in this manual.
- The system must be fitted to allow sufficient room around the ComfoAir for the air connections and supply and exhaust ducts as well as for carrying out maintenance activities.
- The ComfoAir must be installed in a frost-free space. The condensation must be drained off frost-free, at a gradient and incorporate a 'U' bend.

 **We do not recommend installing the ComfoAir in areas with a higher average humidity (such as bathroom or toilet). This will prevent condensation on the outside of the ComfoAir.**

- The room must offer the following provisions:
 - Air duct connections.
 - 230V electrical connection.
 - Provisions for the condensation drain.
 - Wiring for a wired 3-position switch (optional).
- A gap should be left near the doors in order to ensure effective and draughtfree airflow in the house. A gap under the inside doors must be at least 10mm.

 **If these openings are obstructed, due to draught excluders or deep-pile carpet, the airflow in the house will stagnate. As a result, system performance will be compromised or fail altogether.**

2.5 Installation of the ComfoAir

2.5.1 Transport and unpacking

Take the necessary precautions when transporting and unpacking the ComfoAir.

 **Make sure the packing material is disposed of in an environmentally friendly manner.**

2.5.2 Checking the delivery

Contact your supplier immediately in case of damage or an incomplete delivery. The delivery should include:

- ComfoAir;
Check the identification plate to ensure that it is the required type.
- 4 x 45° connection bends;
- Mounting bracket;
- Documentation.

The ComfoAir is supplied in the following types:

Type
ComfoAir 350 L Basic
ComfoAir 350 R Basic

Meaning of the suffixes:

- * L = Left version
- * R = Right version

2.6 Mounting of the ComfoAir

2.6.1 Mounting on the wall

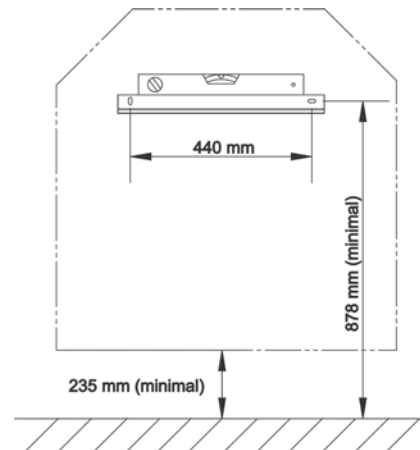

Mount the ComfoAir against a wall with a minimum mass of 200 kg/m². For other types of wall, we recommend using the Zehnder mounting frame on the floor (available as an optional extra). This reduces contact noise as much as possible. The ComfoAir does not require any space at the sides for effective operation.

 **Do not mount the side of the ComfoAir against the wall due to the risk of impact sound.**

1. Fasten the mounting bracket to the wall. Make sure it is level and at least 878mm from the floor (depending on the type of condensation drain selected).

 **Leave a minimum space of 1m in front of the ComfoAir for carrying out maintenance.**

2. Hang the ComfoAir on the mounting bracket.
3. Mount the condensation drain under the ComfoAir. The stated dimension of 235 mm is an indication only, and is dependent on the type of condensation drain selected.

2.6.2 Connection of the air ducts

The following aspects must be taken into account, while installing the air ducts:

- Install the air exhaust duct so it drains in the direction of the ComfoAir.
- Insulate the outside air supply and the air exhaust duct between the roof/wall passage to render the ComfoAir damp proof. This prevents the formation of condensation on the outside of the ducts.
- To prevent unnecessary temperature loss in either the summer or the winter, we recommend fitting thermal and damp-proof insulation to the supply ducts from the ComfoAir up to the supply valves.
- Install the air ducts with a minimum \varnothing of 150 mm, as little air resistance as possible and free from air leakage.
- Install a silencer of at least 1m straight directly onto the supply and return air connections. For relevant advice, please contact Zehnder.
- When using flexible channels only Zehnder channel systems may be used. Any other flexible channel will disturb the basic operating principle of the balanced ventilation system.
- We recommend that the ventilation system is fitted with intake and exhaust valves made by Zehnder.

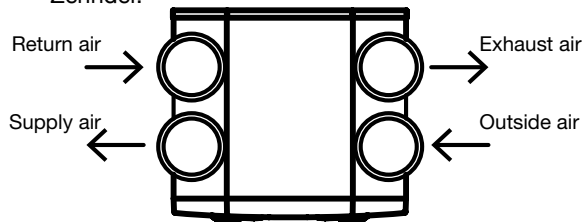

ComfoAir 350 - LEFT

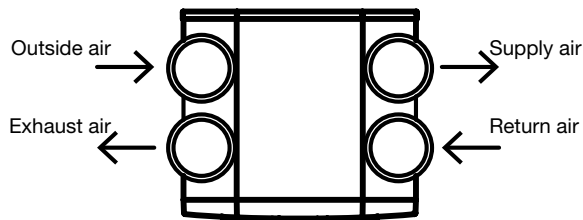

ComfoAir 350 - RIGHT

2.6.3 Connection of the condensation drain

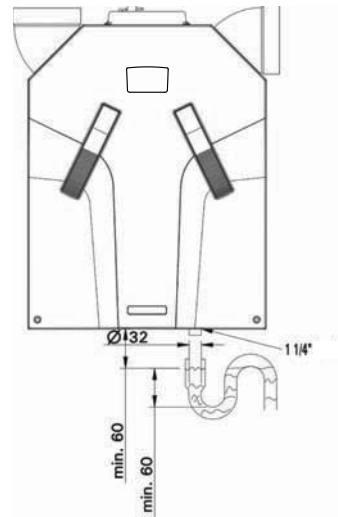

ComfoAir 350 - LEFT

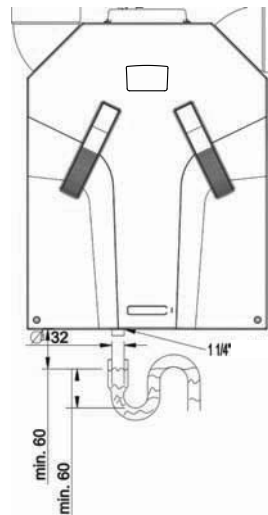

ComfoAir 350 - RIGHT

Warm exhaust air is cooled by the outside air in the heat exchanger. This causes the moisture in the indoor air to condense in the heat exchanger. The condensation water created in the heat exchanger is fed to a PVC condensation drain.

The connection for the condensation drain has an external diameter of 32 mm. It is located underneath the ComfoAir.

- Connect the condensation drain, via a pipe or hose, to the water seal (U bend) of the domestic waste-water system.
- Position the upper edge of the water seal at least 40 mm underneath the condensation drain of the ComfoAir.
- Make sure that the outer end of the pipe or tube exits is at least 60mm below the water level.



Ensure that the water seal connected to the domestic waste-water system is always full of water. This prevents the ComfoAir from sucking in any leakage air.

2.7 Commissioning the ComfoAir

After installation, the ComfoAir must be commissioned.

This can be done via the P menus on the digital operating device. These P menus can be used to enter various settings (ventilation programmes, in particular) for the ComfoAir. An overview of the available P menus is given below:

Menu	Options
P1	Reading statuses (from menu P2)
P2	Setting time delays
P3	Setting and reading the ventilation levels
P4	Setting and reading the temperatures
P5	Setting additional programmes
P6	Setting additional programmes
P7	Reading and resetting malfunctions (and system information)
P8	N/A
P9	Reading statuses (from menu P5 and P6)





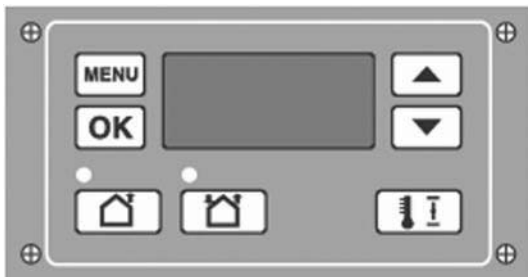

P menus P1, P2 and P9 can be accessed by the user, mainly to read statuses and set time delays. The remaining P menus P3 to P8 are intended **solely** for the installer.

 **The ComfoAir's bypass valve will not work for the first 4 minutes after a power cut unless the programme mode is activated.**







2.7.1 Display on the unit

The ComfoAir can be operated and commissioned by means of a display. The display is a digital operating device which is mounted on the ComfoAir.



	select menu		up
	OK		down
	supply off (led green)		supply on (led green)
	comfort temperature		

Shown in display

	Ventilation setting absent
	Ventilation setting low
	Ventilation setting medium
	Ventilation setting high
	Menu symbol
	Malfunction code (flashes)
	Bypass

Access to the menus

Se-quence	Press	Display	Description
1	MENU	P2	Time delay
2	▲ + ▼ (3 seconds)	P3	Press the buttons simultaneously.
3	▲	P4	Temperatures
4	▲	P5	Settings
5	▲	P6	Settings
6	▲	P7	Malfunction / Reset / Self-test
7	▲	P8	0 - 10V Inputs
8	▲	P9	Status

Example

Setting the MEDIUM POSITION of the supply fan to 40%.

Se-quence	Press	Display	Description
1	MENU	P2	Time delay
2	▲ + ▼ (3 seconds)	P3	Press the buttons simultaneously.
3	OK	P30	Exhaust fan Position A
4	▲ (6x)	P36	Select P36
5	OK	50	Current setting
6	▼ (10 x or press continuously)	40	Select 40
7	OK	P35	Value is 40
8	MENU	P3	
9	MENU	1	Fan setting

 **Some P menus (such as P1 and P9) can only be read.**

Leaving Reading menu

- At action point 6 press "MENU" (instead of "OK").

 **The display can not be used for setting the ventilation positions of the ComfoAir. The arrowkeys are only for setting the additional programmes.**

2.7.2 P menus for the installer

 **Menus with a line at minimum and maximum value are Reading menus.**







Menu P3 → Setting ventilation programmes

Submenu	Description	Ventilation programme values		
		Minimum	Maximum	General Reset
P30	n/a	0% or 15%	97%	nL / HL 15% / 15%
P31	Setting the capacity (in %) of the exhaust fan in <small>LOW POSITION</small> .	16%	98%	nL / HL 35% / 40%
P32	Setting the capacity (in %) of the exhaust fan in <small>MEDIUM POSITION</small> .	17%	99%	nL / HL 50% / 70%
P33	Setting the capacity (in %) of the exhaust fan to <small>HIGH POSITION</small> .	18%	100%	nL / HL 70% / 90%
P34	n/a	0% or 15%	97%	nL / HL 15% / 15%
P35	Setting the capacity (in %) of the supply fan in <small>LOW POSITION</small> .	16%	98%	nL / HL 35% / 40%
P36	Setting the capacity (in %) of the supply fan in <small>MEDIUM POSITION</small> .	17%	99%	nL / HL 50% / 70%
P37	Setting the capacity (in %) of the supply fan in <small>HIGH POSITION</small> .	18%	100%	nL / HL 70% / 90%
P38	Current capacity (in %) of the exhaust fan.	-	-	Current %
P39	Current capacity (in %) of the supply fan.	-	-	Current %

Menu P4 → Reading the temperatures

Submenu	Description	Temperature values		
		Minimum	Maximum	General Reset
P41	Comfort temperature	12 °C	28 °C	20 °C
P45	Current value of T1 (= outside air temperature)	-	-	Current °C
P46	Current value of T2 (= supply air temperature)	-	-	Current °C
P47	Current value of T3 (= return air temperature)	-	-	Current °C
P48	Current value of T4 (= exhaust air temperature)	-	-	Current °C





Menu P5 → Setting additional programmes

Submenu	Description	Additional programme values		
		Minimum	Maximum	General Reset
P50	Activation of the open fire programme.	0 (= No)	1 (= Yes)	0
P51	n/a	0 (= No)	1 (= Yes)	0
	 Always keep this setting on Default.			
P52	n/a	0	3	2
P54	Confirming the presence of a bypass.	0 (= No)	1 (= Yes)	1
	 The standard ComfoAir configuration includes a bypass. Therefore, leave the value at '1'.			
P56	Setting the required air volume in the house. ■ nL: "normal air volume". ■ HL: "high air volume".	nL	HL	HL
	 Setting the air volume is the starting point for programming the air specifications and setting the fans.			
P57	Setting the ComfoAir type. ■ Li = "Left-hand version". ■ Re = "Right-hand version".	Li	Re	Li
	 With delivery the ComfoAir is correctly pre-programmed at the factory.  After a general reset the pre-programming is lost and the setting must be reset. The correct setting is mentioned on the identification plate on top of the ComfoAir.			
P58	n/a	0	1	0
P59	n/a	0 (= No)	2 (= Yes)	0
	 Always keep this setting on Default.			

Menu P6 → Setting additional programmes

Submenu	Description	Additional programme values		
		Minimum	Maximum	General Reset
P60	n/a	0 (= No)	3 (= Yes)	0
	 Always keep this setting on Default.			

Menu P7 → Reading malfunctions (and system information)

Submenu	Description	(Malfunction) information values		
		Minimum	Maximum	General Reset
P70	Current software version.	Version number of the software (without “v”)		
P71	Most recent malfunction.	Code in accordance with alarm and malfunction alert		
P72	Malfunction before the most recent one	Code in accordance with alarm and malfunction alert		
P73	Malfunction before the most recent two	Code in accordance with alarm and malfunction alert		
P74	Resetting malfunction(s) ■ Set value to '1' and press "OK" on the display.	0	1 (= activate)	0
P75	General reset. ■ press "OK" on the display for at least 5 seconds to carry out a general reset. All original software settings are restored following a general reset.	0	1 (= activate)	0
	 After a general reset, the ComfoAir will ask you to reset the “nL / HL” (see P56) and “Li / Re” (see P57) settings.  Following a general reset, all settings and programmes need to be checked and set to the right value.			
P76	Self-testing the ComfoAir	0	1 (= activate)	0
	 <ul style="list-style-type: none"> • The ComfoAir will run at maximum Rotations Per Minute (RPM). • The bypass valve will open and close. 			
P77	Resetting filter dirty counter	0	1 (= activate)	0
	 <p>This resets the counter that triggers a dirty filter alert on the ComfoAir. This allows the filter to be cleaned or replaced before the dirty filter alert appears.</p>			

Menu P8 → N/A

Submenu	Description	Analogue input values		
		Minimum	Maximum	General Reset
850	n/a	0	1	0
851	n/a	0	1	0
852	n/a	0	100	50
853	n/a	0	99	0
854	n/a	0	100	100
855	n/a	0	1	0
856	n/a	0	100	-

2.8 Programming air specifications

After installation, the ComfoAir must be programmed.

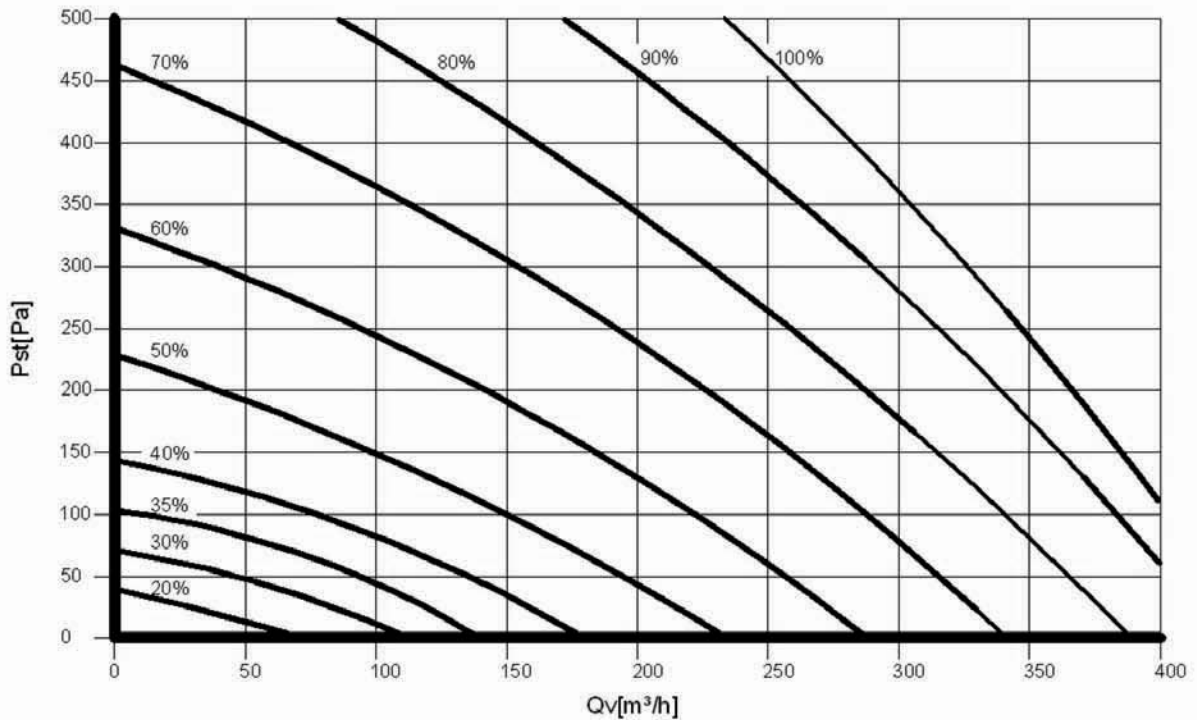

This can be done using the air specifications of the ComfoAir above.



The default settings of the ComfoAir nL are:

Position LOW	35%
Position MEDIUM	50%
Position HIGH	70%

The default settings of the ComfoAir HL are:

Position LOW	40%
Position MEDIUM	70%
Position HIGH	90%

Follow this procedure to programme the ComfoAir (after installation):



- Set the ComfoAir in programming mode.
 - Press simultaneously for at least 3 seconds on "  " and "  " until "InR" appears on the display.

 **In programming mode, the bypass and valve is valves are always closed. After 30 minutes, the ComfoAir automatically terminates the programming mode.**

- Close all windows and outside doors.
- Close all inside doors.
- Check the presence of structural overflow provisions.

- Check if both fans function in the three speed settings.
- Switch the ComfoAir to high speed.
- Install all valves and set the valves according to the settings given or as set in the reference house.
- Change the fan settings in P menus P30 to P37 of the digital operating device if required.

 **Use the chart of the ComfoAir's air specifications to set the fans.**

- In the event that the currently set air volumes still deviate too much: Adjust the valves.
- Check the entire installation again, after all valves have been set.
- Switch the ComfoAir (back) to ventilation position
 - Press simultaneously for at least 3 seconds on "  " and "  " until "InR" disappears of the display.

2.9 Maintenance by the installer

The following maintenance must be carried out by the installer:

- Inspecting and (if necessary) cleaning the heat exchanger;
 - Inspecting and (if necessary) cleaning the fans.
- A concise explanation of these maintenance activities is given in the paragraphs below.

 **Check the condensation drain once every 5 years.**

 **Failure to carry out (periodic) maintenance on the ComfoAir ultimately compromises the performance of the ventilation system.**

2.9.1 Inspecting and cleaning the heat exchanger

 **Check the heat exchanger once every 5 years.**

1. Disconnect the power from the ComfoAir.
2. Remove the handles (B) from the ComfoAir;
3. Remove the filters from the ComfoAir.
4. Release the front panel by unscrewing the screws (C).
5. Slide the front panel upwards and remove the front panel from the ComfoAir.

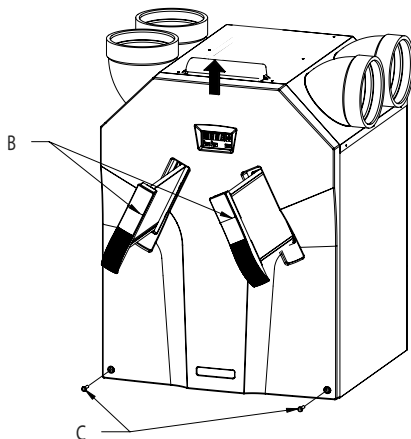

6. Release the cover panel by unscrewing the screws (D).
7. Remove the cover panel.

 **When reassembling the front cover, the lower section must first be inserted behind the raised edge to ensure a good seal.**

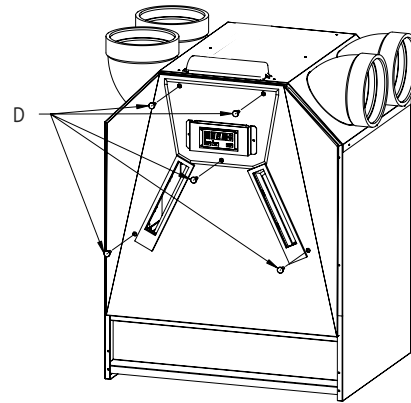

ComfoAir – Left-hand version

8. Pull the strap (E) to remove the heat exchanger and the leakage tray (F).
9. Remove the bypass duct (G) in the **left-hand** version of the ComfoAir.

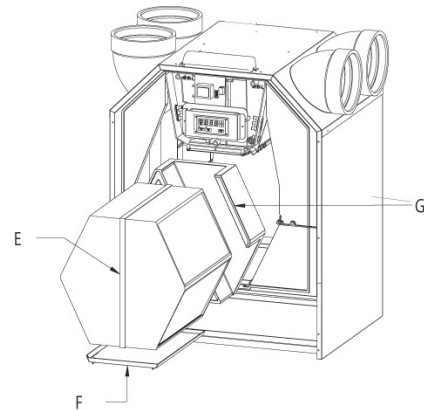

ComfoAir – Right-hand version

8. Remove the bypass duct (G) in the **right-hand** version of the ComfoAir.
9. Pull the strap (E) to remove the heat exchanger and the leakage tray (F).

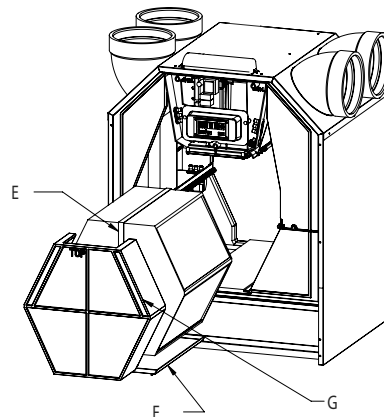

10. Remove the heat exchanger from the leakage tray (F).

 **The heat exchanger may contain some residual water!**

⚠ *When reassembling the leakage tray the openings in the leakage tray must be on the side of the condensation drain.*

11. Inspect and if necessary clean the heat exchanger.
 - Use a soft brush to clean the fins.
 - Use a vacuum cleaner or air gun (no high pressure) to remove dirt and dust.

👉 *Always clean against the direction of the airflow. This prevent dirt from getting stuck in the heat exchanger.*

Standard heat exchanger only:

- a. Submerge the heat exchanger several times in hot water (max. 40 °C).
- b. Rinse the heat exchanger with clean hot tap water (max. 40 °C).
- c. Clasp the heat exchanger between both hands (on the coloured side surfaces) and shake the water from the heat exchanger.

⚠ *Do not use aggressive cleaning agents or solvents.*

👉 *If the fans also need maintenance do not re-install the heat exchanger yet.*

12. If no more maintenance is necessary install all parts in reverse order, reconnect the power and carry out the self-test in accordance with menu P76.

⚠ *Fasten the screws to a maximum of 1.5 Nm. This is roughly equal to speed 2 of an average battery-powered drill.*

2.9.2 Inspecting and cleaning the fans

👉 *Check the fans once every 2 years.*

1. Remove the heat exchanger as instructed in the maintenance chapter of the heat exchanger.
2. Remove the small plastic panel (H) in front of the control circuit board panel by unscrewing the two screws.
3. Release the connectors (K) and the earth wire on the control circuit board panel and fully remove the cables including the two grommets (K).
4. Remove the entire scroll casing (L) by pressing the click fasteners.
5. Remove the inflow nozzle by pressing the click fasteners surrounding the scroll casing.
6. Inspect and if necessary clean the fans.
 - Use a soft brush to clean the fan impellers.
 - Use a vacuum cleaner to remove dust.

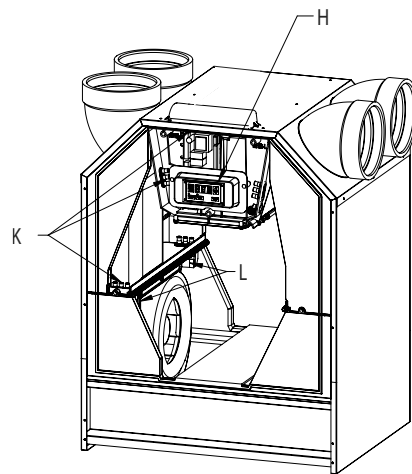

⚠ *Do not damage the fan impellers or temperature sensor.*

7. If no more maintenance is necessary install all parts in reverse order, reconnect the power and carry out the self-test in accordance with menu P76.

⚠ *Fasten the screws to a maximum of 1.5 Nm. This is roughly equal to speed 2 of an average battery-powered drill.*

2.10 Malfunctions

Malfunctions in the ComfoAir are reported as follows:

- The malfunction alert appears on the display;
- The malfunction indicator on the 3-position switch lights up.

Malfunction alerts may not appear on the digital operating device in all cases, even though there is a malfunction (or problem). A concise explanation of both types of malfunction (or problem) is given in the following paragraphs.

2.10.1 Malfunction alerts on the digital operating device

In the event of a malfunction, the corresponding malfunction code will be displayed on the digital operating device of the ComfoAir.

Below is a list of the malfunction alerts on the digital operating device.

In the chapter about troubleshooting is explained how to solve these malfunctions

Code	Description
A1	NTC sensor T1 is defective. (= outside air temperature)
A2	NTC sensor T2 is defective. (= supply air temperature)
A3	NTC sensor T3 is defective. (=return air temperature)
A4	NTC sensor T4 is defective. (= exhaust air temperature)
A5	Malfunction in the bypass motor.
A6	n/a
A7	n/a
E1	Exhaust fan not rotating.
E2	Supply fan not rotating.
EA2	n/a
'Fil' 'tEr'	Internal Filter is dirty.

2.10.2 3-position switch with malfunction indicator

The 3-position switches that are fitted with a malfunction indicator show when a malfunction or filter dirty alert has occurred. In the event of a malfunction or filter dirty alert the indicator lights up;



2.10.3 What to do in the event of a malfunction / Troubleshooting

Below are a number of troubleshooting tips for the malfunction alerts described previously which can appear on the digital operating device in the event of a malfunction.

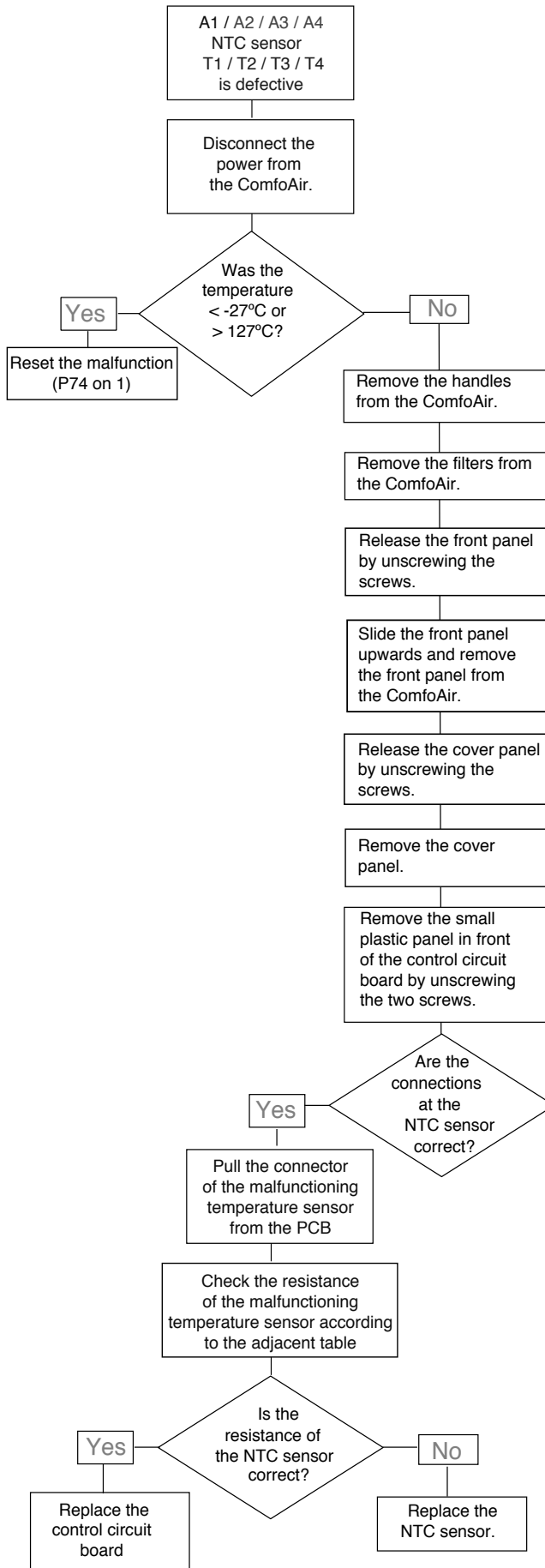

Resistance table for (NTC) temperature sensors:

Temperature [°C]	Resistance [KΩ]		
	MIN.	MID.	MAX.
10	19,570	19,904	20,242
15	15,485	15,712	15,941
18	13,502	13,681	13,861
19	12,906	13,071	13,237
20	12,339	12,491	12,644
21	11,801	11,941	12,082
22	11,291	11,420	11,550
25	9,900	10,000	10,100
30	7,959	8,057	8,155

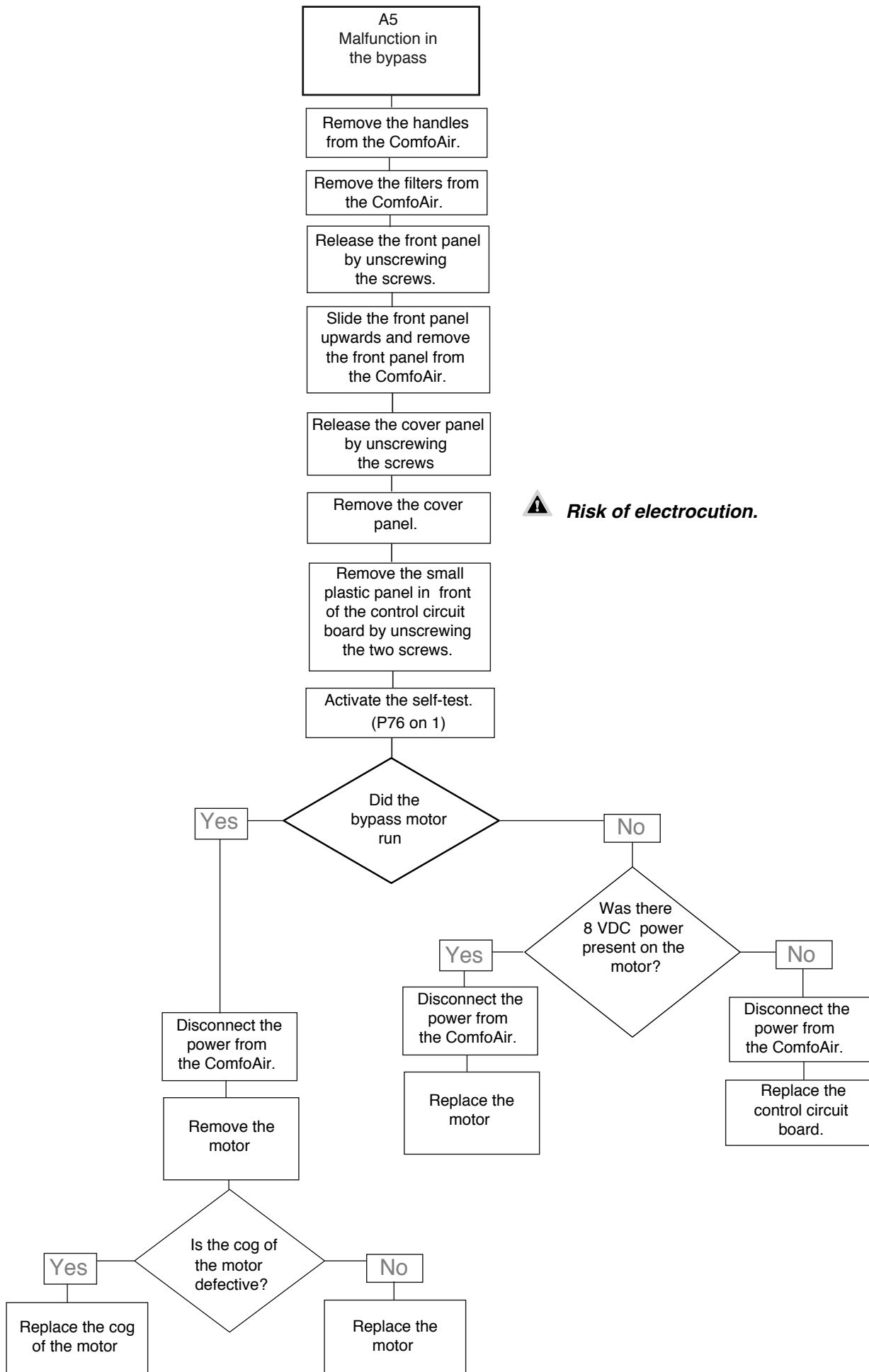

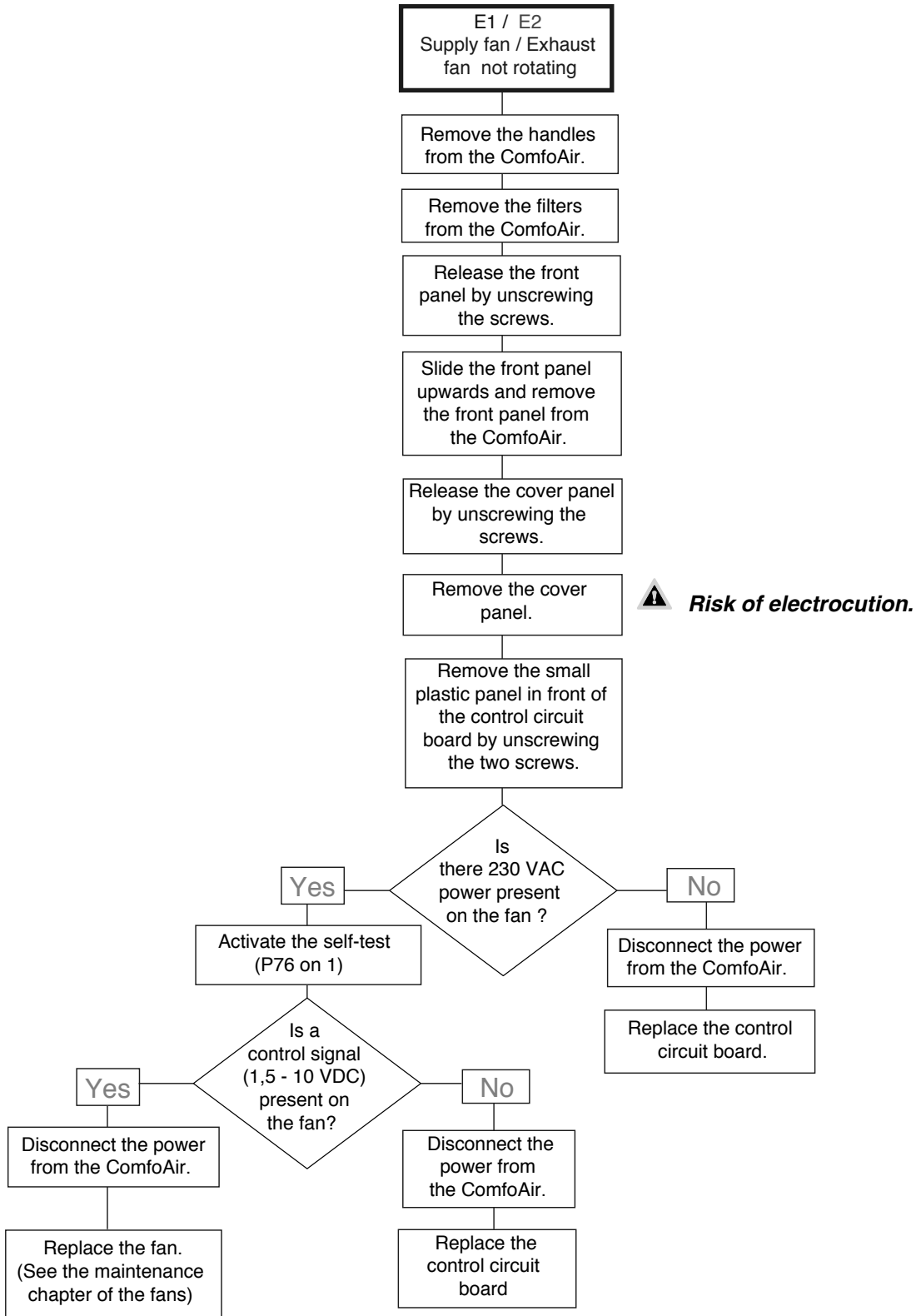
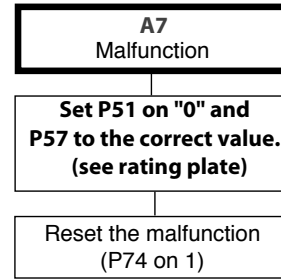
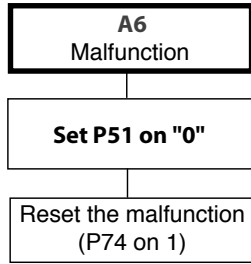

**EA2
Malfunction**

Set P59 at "0".

Reset the malfunction
(P74 on 1)

**,Fil' ,tEr'
Internal Filter is dirty**

Press "OK" on the display for at least 4 seconds until the filter warning disappears.

Disconnect the power from the ComfoAir.

Remove the handles from the ComfoAir.

Remove the dirty filters from the ComfoAir.

Slide the clean (new) filters back into the ComfoAir.
Cleaning: Vacuum the filters with a vacuum cleaner.

Refit the handles to the ComfoAir.

Reconnect the power to the ComfoAir.

2.10.4 Malfunctions (or problems) without alerts

An overview of the malfunctions (or problems) without notifications is given below.

Problem/Malfunction	Indication	Check / action
System switched off	Power supply on	Check the fuse on the control circuit board ■ If the fuse is defective, replace fuse ■ If the fuse is OK, the control circuit board is defective and must be replaced
	No power supply	Mains power is off
High intake temperature in summer	Bypass remains closed	Reduce the comfort temperature
	ComfoAir is still in Winter mode: Bypass remains closed	Checking the Mode of the ComfoAir is possible with special read-out software. ■ Wait until ComfoAir switches to Summer mode
Low intake temperature in winter	Bypass stays open	Increase the comfort temperature
Little or no air supply; shower remains damp	Filters blocked	Replace the filters
	Valves blocked	Clean the valves
	Exchanger clogged by dirt	Clean the exchanger
	Exchanger frozen	Defrost the exchanger
	Fan dirty	Clean the fan
	Ventilation ducts blocked	Clean the ventilation ducts
	ComfoAir is in frost-protection operation	Wait until the weather warms up
Too noisy	Fan bearings defective	Replace the fan (bearings)
	Fan settings to high	Change the fan (settings)
	Slurping noise ■ U bend. is empty ■ U bend. does not seal properly	Reconnect the U bend
	Whistling noise ■ An air gap somewhere	Seal the air gap
	Airflow noise ■ Valves do not close onto duct. ■ Valves not open far enough	Reinstall the valves Reset the valves
	Condensation leak	Unblock the condensation drain
Corded 3-position switch not working	Condensation drain clogged	Check whether the connections are correct
	Cabling is not correct Switch is defective	Check the wiring circuit of the 3-position switch by measuring the voltage: ■ Voltage only on N & L3: [Fans rotate in position 1] ■ Voltage only on N & L3 & L2: [Fans rotate in position 2] ■ Voltage only on N & L3 & L1 or N & L3 & L2 & L1: [Fans rotate in position 3]

2.11 Service parts

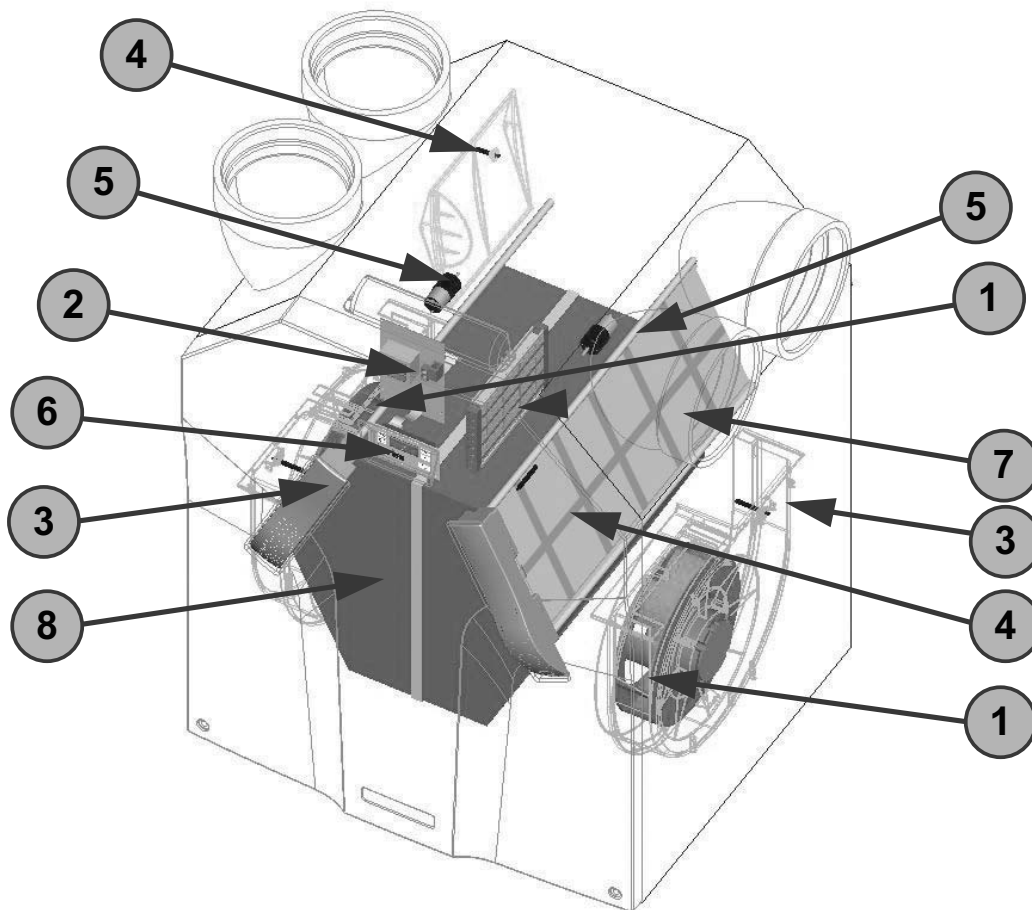

The following table contains an overview of the spare parts available for the ComfoAir.

Number	Part	Article number
1	Fans (left and right)	400200010
2	ComfoAir 350 control circuit board	400300010
3	Temperature sensor T2 / T4 (fans)	400300040
4	Temperature sensor T1 / T3 (bypass)	400300030
5	Servo motor & cable (for the bypass)	400300050
6	Display	400300020
7	Air filterset G4/G4	400100085
7a	Filter handle	400100029
8	Heat exchanger	400400010
	Wireless 3-position switch with malfunction indicators	655000755
	3-position switch with malfunction indicators	659000300
	Floor mounting frame	642300135

2.12 Wiring diagram: ComfoAir 350 Basic – LEFT-HAND version

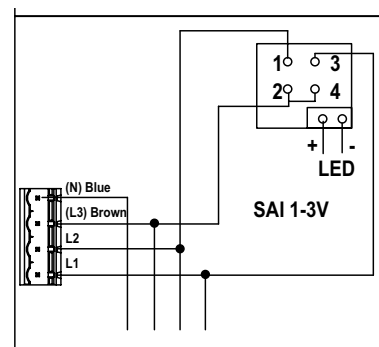
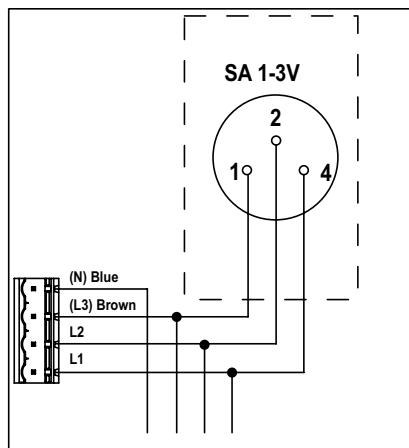
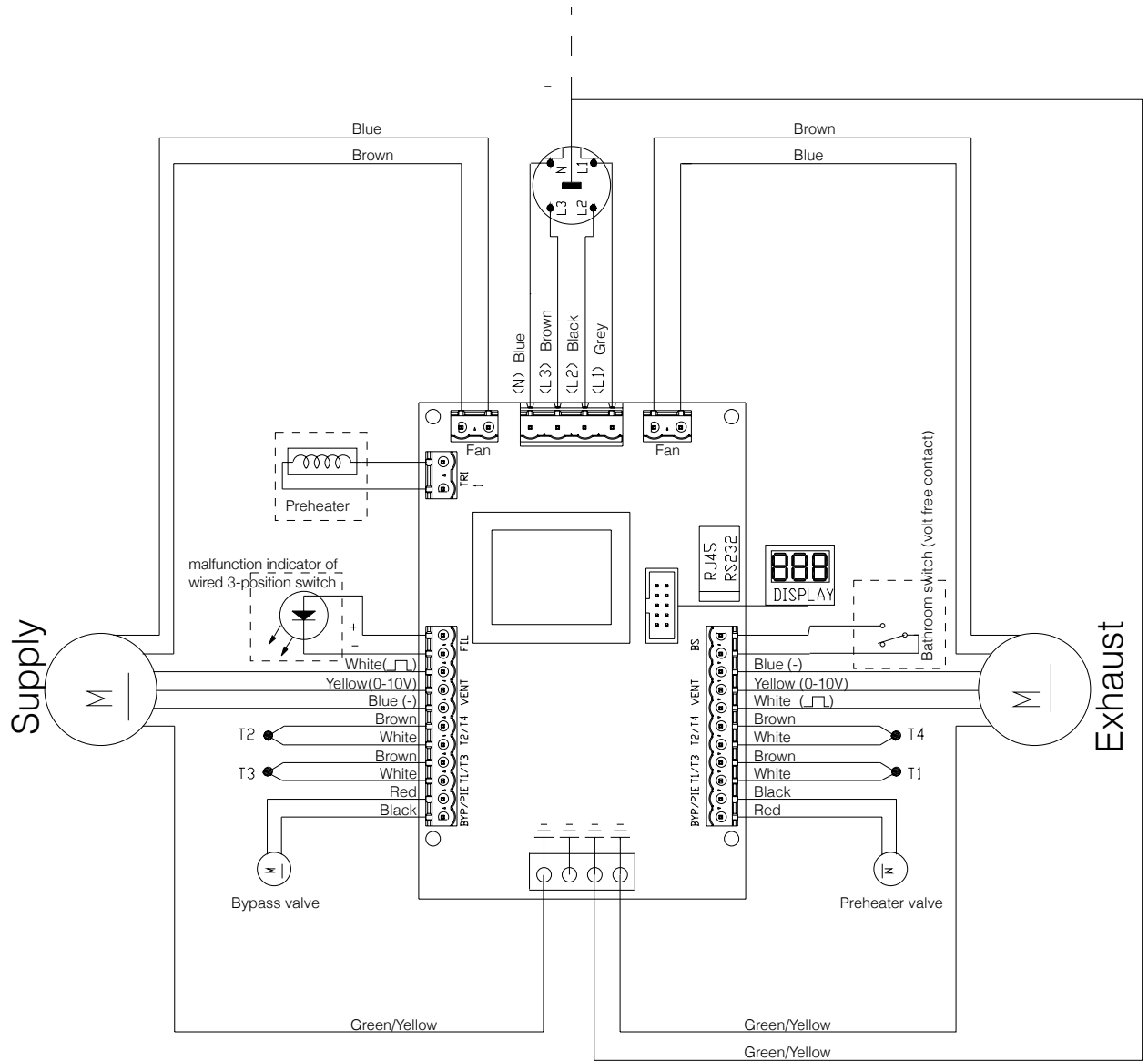

2.13 Wiring diagram: ComfoAir 350 Basic – RIGHT-HAND version

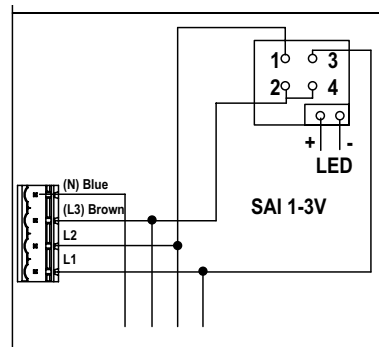
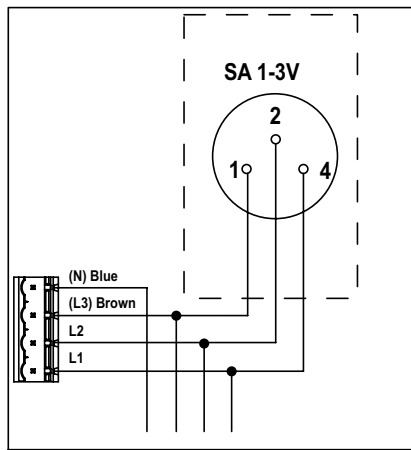
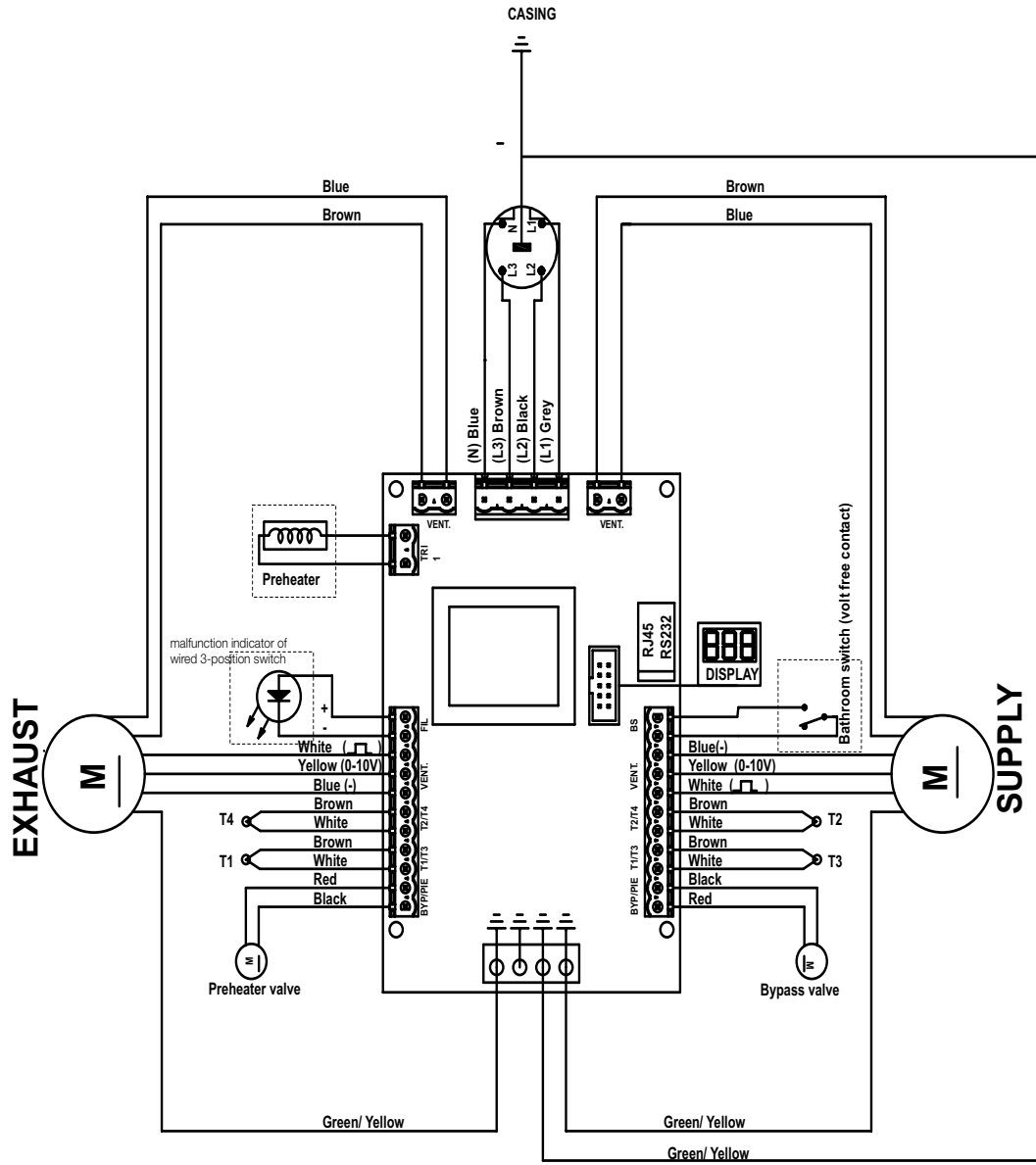

2.14 EEC declaration of conformity

Zehnder Group Nederland B.V.
Lingenstraat 2
8028 PM Zwolle-NL
Tel.: +31 (0)38-4296911
Fax: +31 (0)38-4225694
Company register Zwolle 05022293

EEC declaration of conformity

Machine description

: Heat recovery units: ComfoAir 350 series

Complies with the following directives

: Machinery Directive (2006/42/EEC)
Low Voltage Directive (2006/95/EEC)
EMC Directive (2004/108/EEC)

Zwolle, 5 January 2010
Zehnder Group Nederland B.V.

A handwritten signature in black ink, consisting of a large, stylized initial 'E' followed by a series of vertical strokes and a horizontal line extending to the right.

E. van Heuveln,
Managing Director





